

**SEUIC**

# Reference Manual

CRUISE2 5G

5G Digital Mobile Phone

User Manual of Android System

Version 1.2

## **Copyright Statement**

The information in this manual is provided "as-is", which is subject to change without notice.

SEUIC offers no warranty of any kind, implied or otherwise, including without limitation, any warranty of merchantability or fitness for a particular purpose. In no event shall SEUIC be liable for any incidental or consequential damages of any kind, or any damages whatsoever resulting from errors herein, or arising out of or in connection with the provision, performance or use of this manual.

Software copyright © **2019 -2022 SEUIC Company**

The proprietary information protected by copyright is present in this manual. All rights reserved. Except as permitted by copyright law, without the prior written consent of SEUIC, any portion of this manual may not be photocopied, republished, adapted or translated.

The copyrights of this manual and related application software are the property of SEUIC and protected by the copyright laws of People's Republic of China and international copyright laws.

The brand names and product names mentioned herein are the trade names, service logos, trademarks or registered trademarks of their respective holders.

To seek for more product information and support, please contact our sales representative, or log onto our website.

SEUIC Technologies Co., Ltd.

Add.: No. 15, Xinghuo Road, Jiangbei New Area, Nanjing City, Jiangsu Province

P.O.: 210061

Tel.: 86-25-52261298

Fax: 86-25-52268995

Enterprise website: [www.SEUIC.com](http://www.SEUIC.com)

Product website: [www.ChinaAUTOID.com](http://www.ChinaAUTOID.com)

Service hotline: 400-677-0876

Service e-mail: [AUTOID@SEUIC.com](mailto:AUTOID@SEUIC.com)

## Contents

Chapter I Operation instructions .....	1
1.1 Precautions for laser scan engine .....	1
1.2 Precautions for safety .....	1
1.3 Precautions for maintenance .....	1
Chapter II Overview .....	2
Chapter III Keyboard .....	3
Chapter IV Quick start .....	4
4.1 Initial operation .....	4
4.2 Power on .....	4
4.3 Power off .....	4
4.4 Restart .....	4
4.5 Installing SIM card .....	4
4.6 Installing SD card .....	5
Chapter V Charging .....	6
5.1 Charging time .....	6
5.2 Charging temperature .....	6
5.3 Powered by battery .....	6
5.4 Precautions for batteries .....	7
5.5 LED indicators .....	7
Chapter VI Homepage .....	8
6.1 Icons on status bar .....	9
Chapter VII Settings .....	10
7.1 WLAN .....	10
7.2 Mobile network .....	12
7.3 More .....	13
7.3.1 Flight mode .....	13
7.3.2 NFC .....	13
7.3.3 Network sharing and portable hotspot .....	14
7.3.4 VPN .....	15
7.3.5 Mobile network .....	15
7.3.6 Resetting network .....	17
7.4 Display .....	18
7.5 Notification .....	20
7.6 Vice .....	21
7.7 Application .....	21
7.8 Storage .....	22

7.9 Battery .....	23
7.10 Location information .....	24
7.11 Security .....	24
7.12 Account .....	25
7.13 Language and input method .....	25
7.14 Backup and reset .....	26
7.15 Date and time .....	27
7.16 Barrier-free function .....	28
7.17 Developer options .....	28
7.18 About the phone .....	29
Chapter VIII Introduction of typical applications .....	31
8.1 Scanning tool .....	31
8.2 System upgrade .....	36
8.3 Mobile Butler .....	39
8.4 Quick configuration .....	45
8.4.1 Import .....	45
8.4.2 Export .....	48
8.5 Featured settings .....	50
8.5.1 Touch display glove mode .....	51
8.5.2 Disabling status pull-down .....	51
8.5.3 Disabling transfer of key value from scan key to applications .....	51
8.5.4 Displaying scan Floating Action Key(FAB) .....	52
8.5.5 Disabling drop detection .....	52
8.6 Whitelist of digital certificates .....	52
Chapter IX Troubleshooting .....	55
Optional accessories .....	57

## Chapter I Operation instructions

### 1.1 Precautions for laser scan engine



Laser radiation! Users should not look directly at the laser beam.

### 1.2 Precautions for safety

- The device can only be powered by the battery and charged with the charger specified by SEUIC; otherwise, there is a risk of liquid leakage, overheat, burst and fire of the battery.
- It is forbidden to short-circuit the charger; otherwise it will cause electric shock, smoke and damage to the charger.
- Do not use the charger when the power cord is damaged; otherwise it may cause fire and electric shock.
- Do not disassemble or modify the charger; otherwise, it will cause personal injury, electric shock, fire and damage to the charger.
- Hold the charger when pulling out the plug. Pulling the power cord will damage the wire, causing electric shock and fire.
- Clean the device, battery and charger with the soft dry fabric.
- Do not wipe the device with the alcohol, thinner or benzene-based solutions.

### 1.3 Precautions for maintenance

- This product features water-proofing and dust-proofing, but the operation in extremely high temperature, extremely low temperature or wet environment still needs to be avoided. Refer to the temperature and humidity criteria in the product specifications.
- Pressing hard on the display may cause damage to it. Do not use a resistive stylus to tap the display in case of scratch or damage on the display. To clean the display, spray a small amount of LCD display cleaner available on market on a soft fabric. Avoid spraying the cleaner directly on the display.
- Do not use any chemical cleaners to wipe the LCD display.
- Keep the scan window clean and free of stains; do not scratch it with sharp objects.
- If you do not use this product for a long time, download the data to the PC for storage.
- The battery in the device will take a long time to be fully charged when it is out of use for the first time or when it is put into use after storage.
- If you find some fault, please write down the information about the occurrence and contact the repairer.

Chapter II Overview

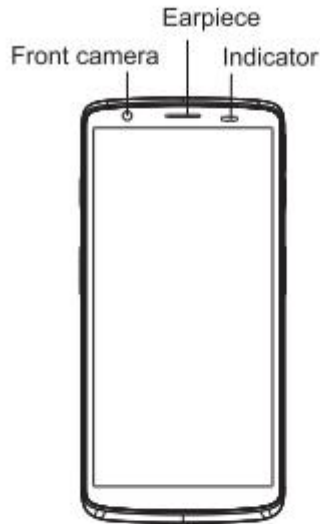

Fig. 1



Fig. 2

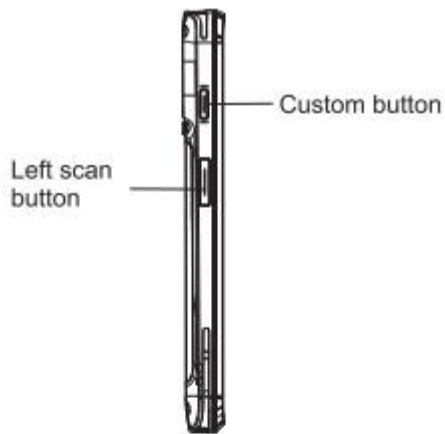

Fig. 3

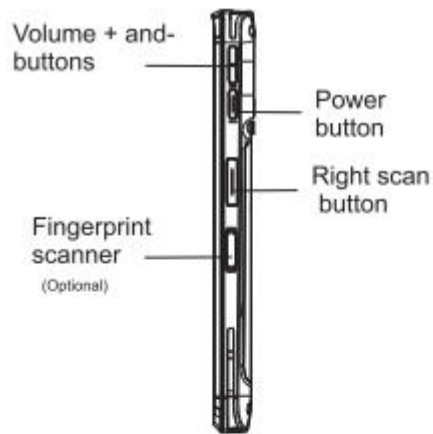

Fig. 4

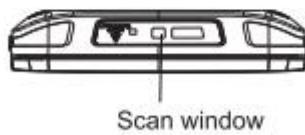

Fig. 5

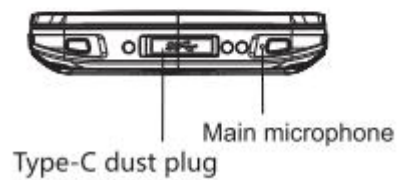











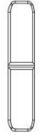





Fig. 6

### Chapter III Keyboard

There are a total of 7 keys on the CRUISE2 device, including 3 virtual keys on the touchpad on the display (Back, Home and Menu) and 4 keys on the side of the device (PPT key, volume key, left scan key, right scan key respectively) ).

Description of keys:

Table 3-1 Introduction of keys

Key	Main function	Description
	Home key	Tap the  key to return to the homepage.
	Menu key	Click the  key to open the task manager.
	Back key	Click the  key to return to the previous interface or exit the application. In the text input interface, tap the  key to close the on-display keyboard.
	Power key	Press the  key in standby state to put the device into sleep/wake up the device; press and hold the  key for 3 seconds in shutdown state to turn on the device
	Volume key	Press the upper half of the  key to increase the volume, and press the lower half of the  key to decrease the volume
	Scan key	Press the  key and the scan head starts to emit light
	PPT key	Reserved key to be defined by the user

1. Screenshot shortcut: press the power + volume - key simultaneously  
2. Home key, Menu key and Back key are all virtual keys

## Chapter IV Quick start

### 4.1 Initial operation

- Press and hold the Power key for 3 seconds to turn on the device; when the system is working, press the Power key, and the device will be put into the sleep mode; in the sleep mode, press the Power key, and the system will be waken up and the display will be lit up.

### 4.2 Power on

- You can turn on the device by pressing the Power key. In deep sleep mode, press the Power key to wake up the system. If the device is powered by a battery, it must be ensured that the battery has been contacted reliably.

### 4.3 Power off

- When the device is turned on and not in sleep mode, press and hold the Power key for 2 seconds to open the option menu; select the power off option, and click the OK button to shut it down properly.

### 4.4 Restart

- When the device is turned on and not in sleep mode, press and hold the Power key for 2 seconds to open the option menu; select the restart option, and click the OK button; then the device will be shut down and restarted properly.

### 4.5 Installing SIM card

- Please follow the instructions below to install the SIM card:
  - Place the SIM card in the tray in the direction as shown in Fig. 4.1.
  - Insert the card tray in the direction as shown in Fig. 4.2.

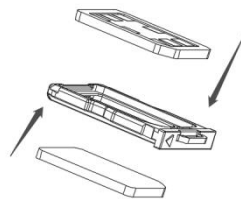

Fig. 4-1 Place the SIM card



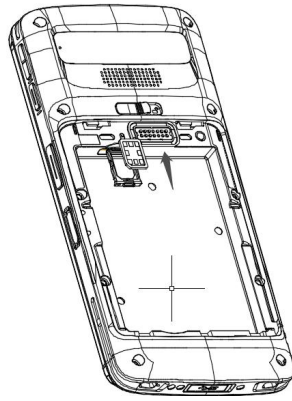

Fig. 4-2 Insert the SIM card

#### 4.6 Installing SD card

- Please follow the instructions below to install the SD card:
  - Insert the SD card into the SD card slot in the direction as shown in Fig. 4.3.
  - Compatible with SD cards with a maximum memory capacity of 128GB

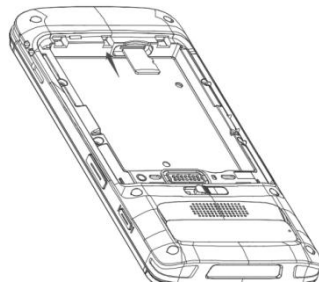

Fig. 4-3 Place the SD card

Note: 1. The SIM card of this device is only compatible with NANO card.

## Chapter V Charging

- As the battery power is low, which is only enough for testing when it is delivered, you must charge it before using it upon reception.

### 5.1 Charging time

- Battery: It takes about 2 hours to fully charge the battery for the first time with the adapter. The LED indicator will be red when the battery is being charged, which will be green when the battery is fully charged.

### 5.2 Charging temperature

- The best operating temperature is room temperature 18°C~25°C.
- The battery will not be charged if the temperature is lower than 0°C or higher than 55°C.

### 5.3 Powered by battery

- If the wireless network service or data acquisition program is enabled, the battery power will be greatly depleted. When such functions are not in use, make sure to disable such programs to save power.
- Tips: If the product will be out of use for a long time, please charge the whole device at least once every two months.

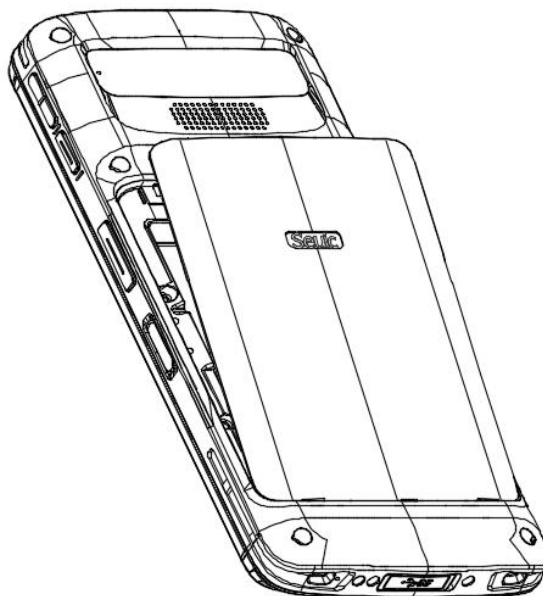

Fig. 5-1 Load the battery

#### 5.4 Precautions for batteries

- If the battery is out of power, the device cannot be turned on immediately when the charger is just plugged in, which is normal. Please keep charging the battery for a period of time, and then turn it on again.
- The battery can be recharged repeatedly, but it is the consumable part. If you find that the standby time of the device is greatly reduced, please replace the battery with a new one.
- Battery charging time varies with temperature conditions and battery usage; please charge the battery within a reasonable temperature range.
- When the battery power is low, the device will pop up a low power prompt. When the battery power is too low, the device will be automatically shut down.

#### 5.5 LED indicators

- The LED indicator in the middle of the upper right corner of the device is used to indicate the battery power status and charging status of the device with different colors:
  - ✧ When the USB, charging adapter or charging connector is not plugged, the red indicator will flash to indicate that the battery power is too low. Please charge it in time;
  - ✧ When the USB, charging adapter, and charging connector are plugged, the red indicator will be always on to indicate that the battery is being charged;
  - ✧ When the USB, charging adapter, and charging connector are plugged, the green indicator will be always on to indicate that the battery is fully charged.
- The LED indicator in the middle of the upper right corner of the device will flash in blue (in the form of a BLN light), indicating that there is unread information; please check it in time.
- The LED indicator on left in the upper right of the device will flash in red once when the barcode is scanned, which will not light up if the barcode is not scanned.

Note: When the system is being charged, the blue indicator will not on for prompt.

## Chapter VI Homepage

Look for this icon  , Settings—Apps and Notifications—Default Apps, and tap the App on the homepage to display the settings homepage. There are two homepages by default, which can be set at will.

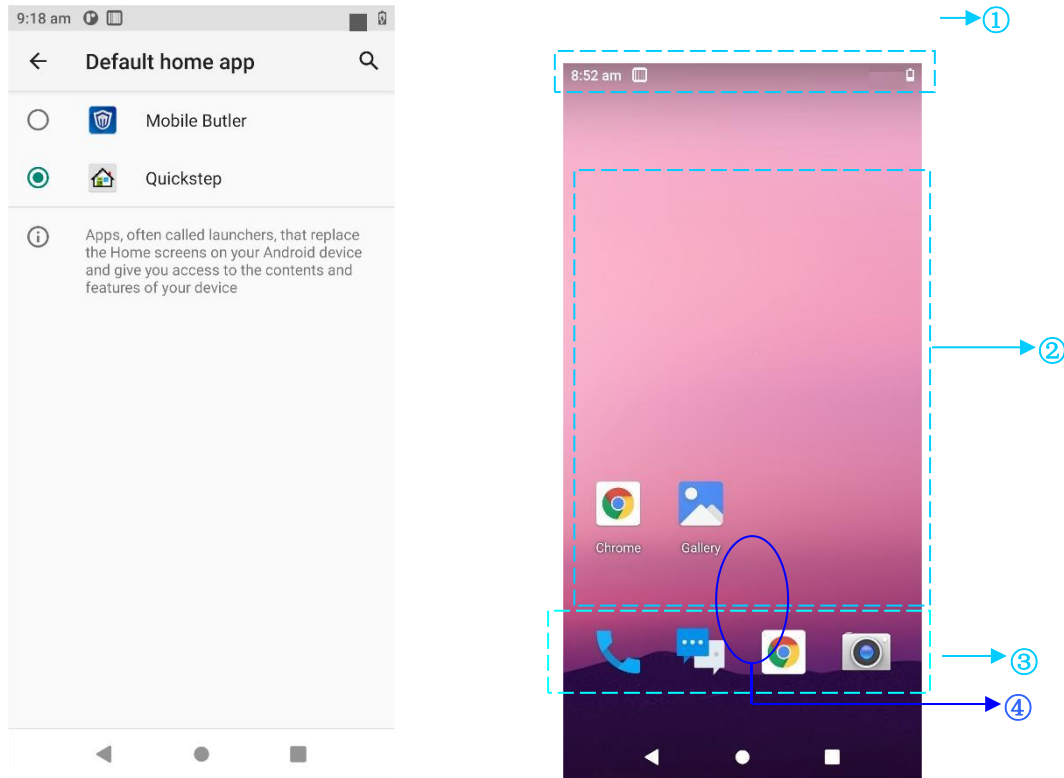

Fig. 6-1 Homepage (Trebuchet)

Table 6-1 Items on the homepage

① Status bar: The notification and status icons are displayed on the status bar.
② Display area: The application icons, desktop folders and widgets are available there.
③ Shortcut bar: Click it to enter the corresponding application.
④ Application tray: Tap or swipe up to enter the homepage to view all programs.

### 6.1 Icons on status bar

The icons on status and notification bar are located in the status bar at the top of the display, displaying status information and notifications as shown in the table below.

Icon	Description	Icon	Description
	Available WLAN found		Signal intensity
	WLAN connected		No SIM card inserted
	Uploading data		Downloading data
	Portable WLAN enabled		Mobile network connected
	DND mode		Flight mode
	Vibration mode		Scan on
	Missed call		Battery being charged
	New notifications		Battery fully charged
	Display image captured		Low battery power
	Alarm clock		Headset plugged
	Preparing microSD card		
	USB debugging, USB connection		

Table 6-2 Status icons and notification bar icons

## Chapter VII Settings

### 7.1 WLAN

Find this icon: 

->Settings

->Network and Internet

->WLAN

Wi-Fi 2.4G covers a wireless network access range up to 450 feet (150m), and 5G covers up to 300 feet (100m) of wireless network access range (Note: industrial-grade AP in open area). To use Wi-Fi on the device, you must connect to a wireless access point or [hotspot].

Attention: The availability and coverage of Wi-Fi signals depend on the number, infrastructure, and other objects through which the signal penetrates.

Enable Wi-Fi and connect to the WLAN

1. Tap the Wi-Fi off/on key to turn on Wi-Fi. The device will automatically scan and search for available WLANs.

2. Then in the WLAN list, the network name and security setting (open network or encrypted network) of the found WLAN will be displayed.

3. Tap one of the WLANs to connect it. When you select an open network, the device will be automatically connected to that network. If you select an encrypted network, you have to enter the corresponding password first before connecting to it.

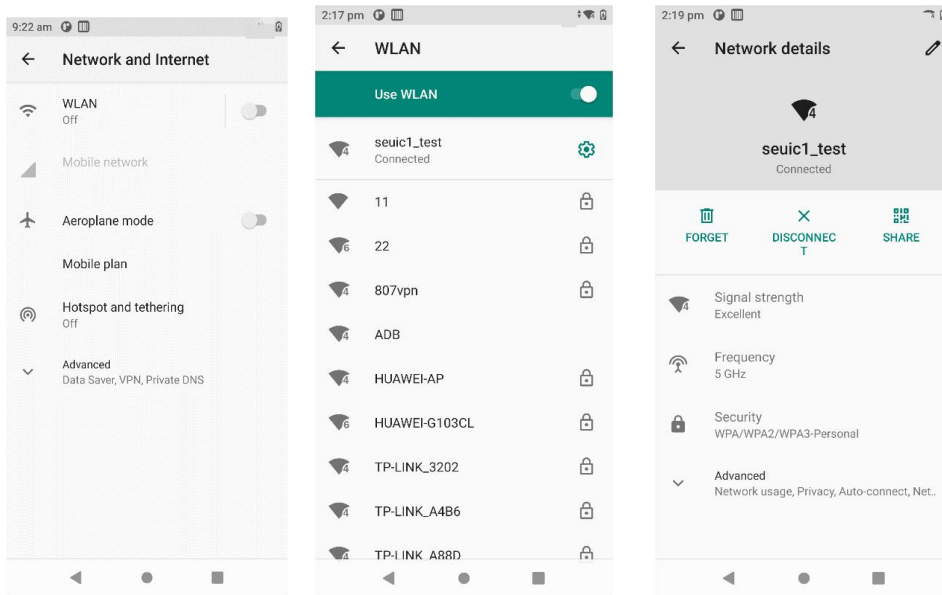

Fig. 7-1 Wi-Fi menu

4. WALN frequency band settings (Click the WLAN preferences at the bottom of WLAN- Click the Advanced option-Click the WLAN advanced settings- Click WLAN frequency band settings); When only 5GHz/2.4GHz frequency band is selected, only 5GHz/2.4GHz frequency band AP can be searched.

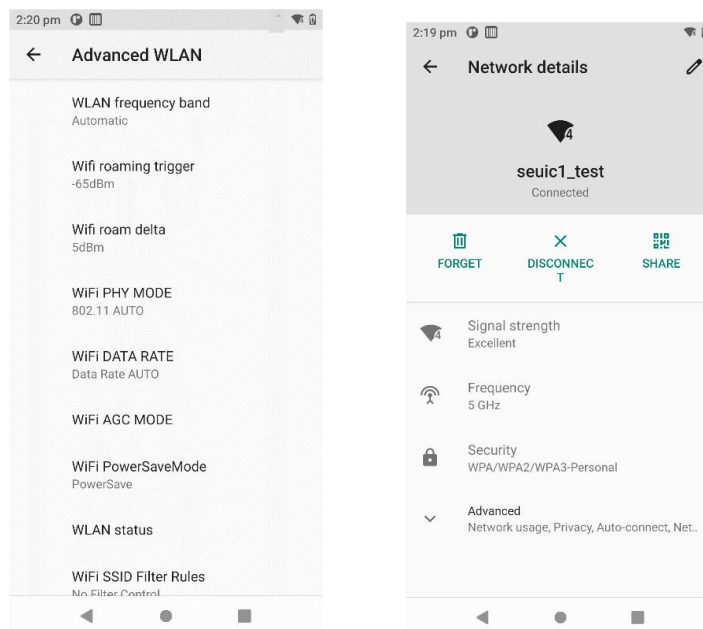

Fig. 7-2 WLAN frequency band

- Open the interface on the wireless Wi-Fi, and tap the scan option. The found WLAN will be displayed in the WLAN list.
- Tap another WLAN to connect to it.

## 7.2 Mobile network

Find this icon:



->Settings

->Network and Internet

->Mobile network

On the SIM card interface, the preferred SIM card (including data traffic, calls, and SMS) can be set, and the SIM function can be disabled. The main interface is shown in the figure below:

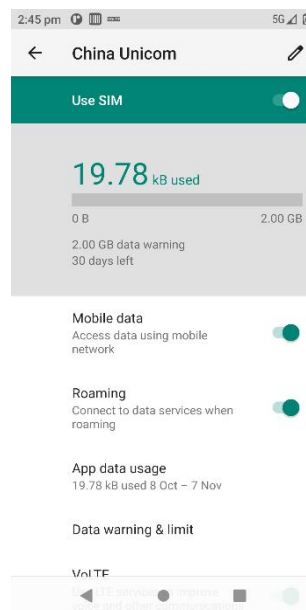



Fig. 7-8 Main interface of SIM card



### 7.3 More

Find this icon: 

->Settings

->Network and Internet

->Advanced

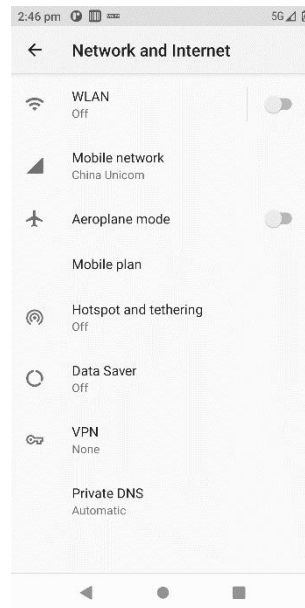

Fig. 7-9 More menu

#### 7.3.1 Flight mode

After checking the flight mode, the wireless module will be automatically disabled.

#### 7.3.2 NFC

Enable the NFC function to allow the mobile phone to exchange data with other devices in the proximity; as long as your device and another device compatible with NFC are near to each other, you can synchronize the applications on your device and share them. Moreover, the third-party NFC software can be installed for reading and writing on NFC card.

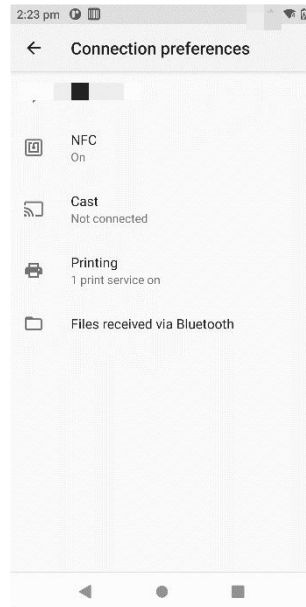

Fig. 7-10 NFC function

### 7.3.3 Network sharing and portable hotspot

(1) With the portable hotspot function, this device can be used as a Wi-Fi hotspot to provide signal access for mobile phones and PCs equipped with Wi-Fi modules in a certain range around.

(2) Settings -> Network and Internet -> Hotspot and Network Sharing -> WLAN Hotspot -> Enable as shown in the figure:

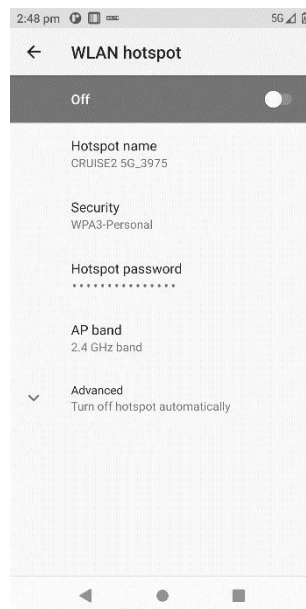

Fig. 7-11 Modify WLAN hotspot

This interface can be modified by clicking on the place that needs to be modified.

### 7.3.4 VPN

After the VPN is enabled, you need to add a VPN by yourself (for example, accessing the file server of intranet and other shared resources on the internet); you can connect to the VPN server of your company via the VPN client regardless of your whereabouts; after obtaining the VPN account number, you can dial via the VPN client. After that, you can access the shared resources of your company.

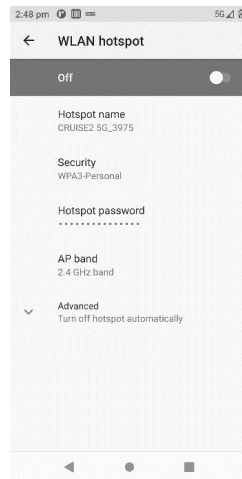

Fig. 7-12 VPN settings

### 7.3.5 Mobile network

1. Enable: After getting into the roaming environment, the data communication can be directly switched to the roaming mode.

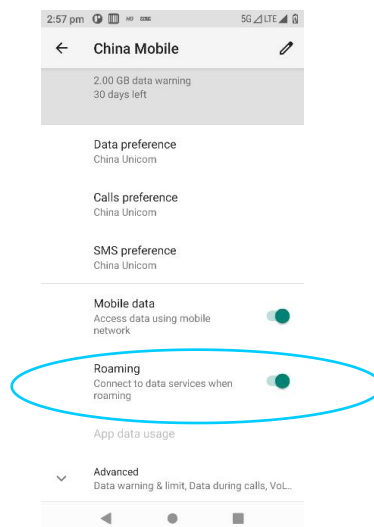

Fig. 7-13 Roaming of mobile data network

2. Preferred network type: After the corresponding preferred network type is selected, the corresponding network signal indication with G=2G preferred, 3G=3G preferred, 4G=4G preferred, 5G=5G preferred will be displayed on the task bar; if the preferred network type 2G is selected for the Unicom card, the device will be forced to connect to the 2G network even if the area is covered by the 3G signal. The CRUISE2 is designed with dual-card dual-standby mode, so the primary and secondary cards can be switched through the data preference setting.

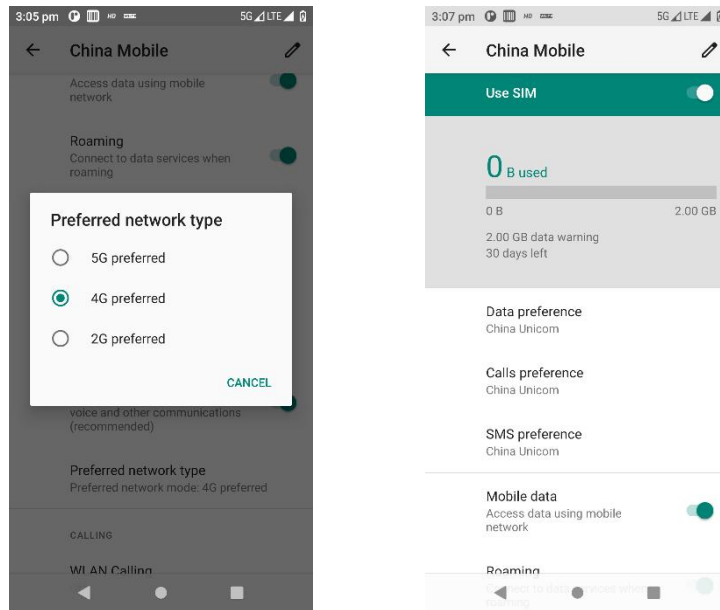

Fig. 7-14 Selection of network mode

3. The name of the access point is generally cmnet for China Mobile by default, 3gnet for China Unicom by default, and ctnet for China Telecom by default as shown in the figure:

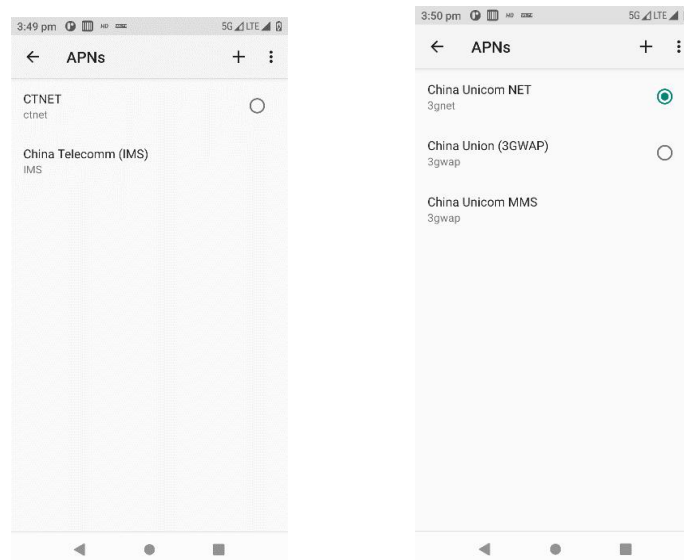



Fig. 7-15 Access point name (APN)

4. To add a dedicated APN, click the  key to pop up the interface as shown in the figure below, where the name (custom), APN (network access point), user name, password, etc. can be generally added; press the Menu key to select the save option and complete the addition; press the Menu key to select the cancel option or press the Back key to go back directly without saving. To modify or delete the added APN, click the enter button to modify it and press the Menu key to save or delete it.

Note: When adding APN, users can make corresponding settings for other options based on their own requirements for access point.

5. Network operator: Search for network operator resources in the current environment.

### 7.3.6 Resetting network

This function can be used to reset some settings of Wi-Fi, mobile network on the device. Click the [Reset settings] key to redirect to the whether to reset the network settings interface, and click the [Reset settings] key; there will be a prompt that the reset is successful as shown in the figure below:

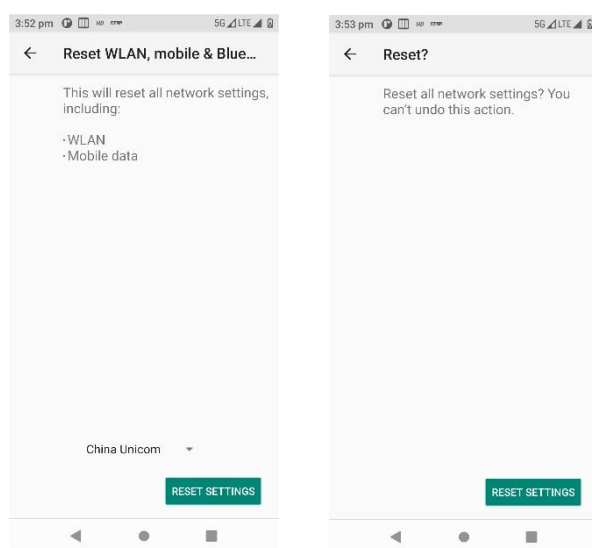



Fig. 7-16 Resetting network

Note: 1. The device is connected to wifi. After resetting the network, the device will clear the AP password and get disconnected;

2. Enable the enhanced 4G LTE mode in the mobile data network. After resetting the network, the the enhanced 4G LTE mode will be enabled on the device by default;

## 7.4 Display

Find this icon: 

->Settings

->Display

1. Brightness: You can move the cursor bar left and right to adjust the brightness of the backlight.

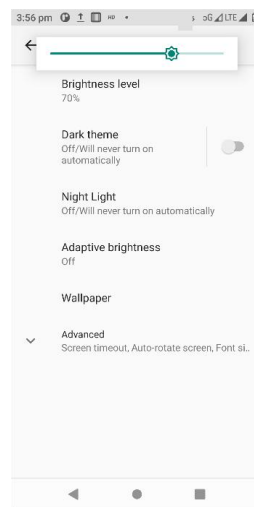

Fig. 7-17 Display

2. Wallpaper: After booting, you can modify the source of the wallpaper at will, such as the pictures and wallpapers in the image library, album or memory card; the system comes with images by default.

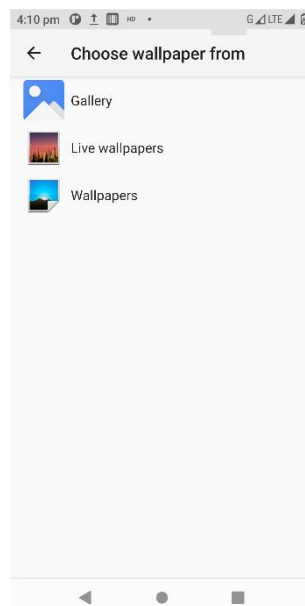

Fig. 7-18 Wallpaper

3. Automatic rotation of the display: The content can be displayed in the direction set; when the device is rotated, the content will be displayed in horizontal and vertical display based on the rotation angle.

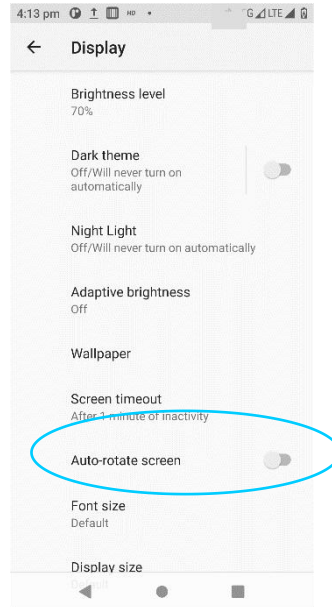

Fig. 7-19 Automatic rotations of the display

4. Sleep over a long time without operation: The system sleep time can be set. After the set time expires, the system will automatically sleep.

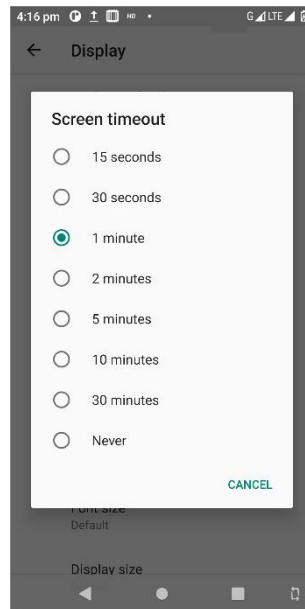

Fig. 7-20 Sleep

5. Font size: The system font size can be adjusted according to your needs, which has the small, default, large and maximum size.

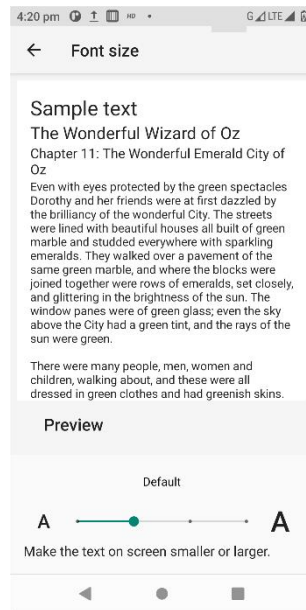

Fig. 7-21 Font

## 7.5 Notification

Find this icon:



->Settings

->Apps and notifications

There are notification message settings for the applications, including notifications, default applications, application permissions, and special application permissions as shown in the figure below:

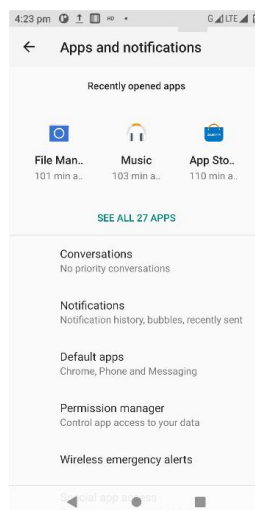





Fig. 7-22 Notification

### 7.6 Vice

Find this icon: 

->Settings

->Voice

There are settings for volume, ringtone and default notification tone; you can also enable, disable, select or cancel vibration when ringing, voice for dial and keyboard operation, prompt voice for touch screen, charging, lock display and vibration for touch as shown in the figure below:

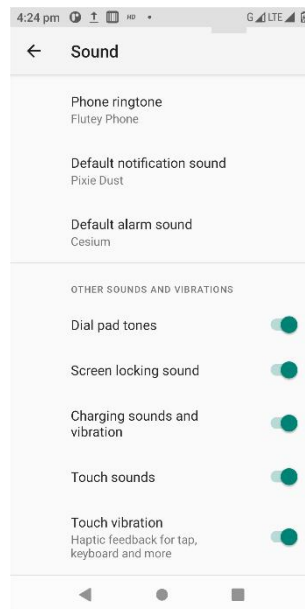



Fig. 7-23 Voice

### 7.7 Application

Find this icon: 

->Settings

->Apps and notifications

To manage the applications, in the interface, click the application you want to uninstall; you will go to the following application information interface; click the uninstall button, and then you can remove the application from the device.

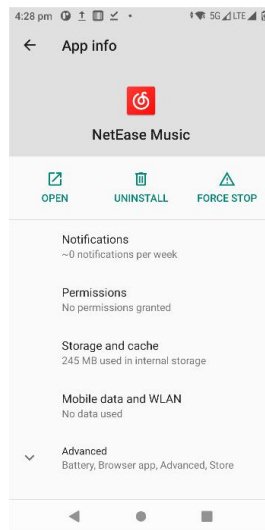

Fig. 7-24 Application

## 7.8 Storage

Find this icon:



->Settings

->Storage

To check the available storage space, you can clear the memory card (format the internal memory) and select the option to scan the external memory card or external USB device.

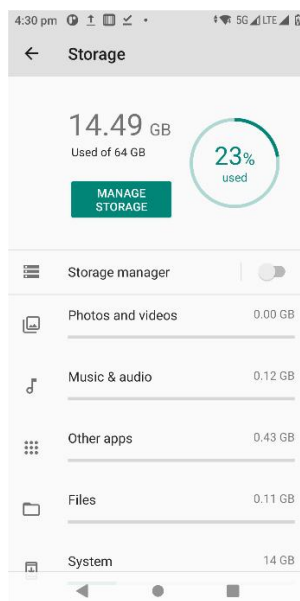



Fig. 7-25 Storage

## 7.9 Battery

Find this icon: 

->Settings

->Battery

You can check the current power of the battery, open and close the status bar to see whether the power is displayed.

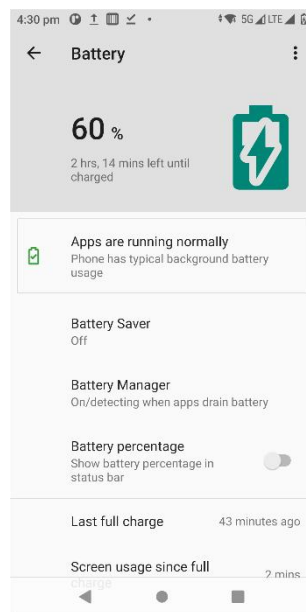



Fig. 7-26 Battery

## 7.10 Location information

Find this icon: 

->Settings

->Location information

To obtain the location where the device is used, enable the GPS positioning function and you can download third-party positioning software.

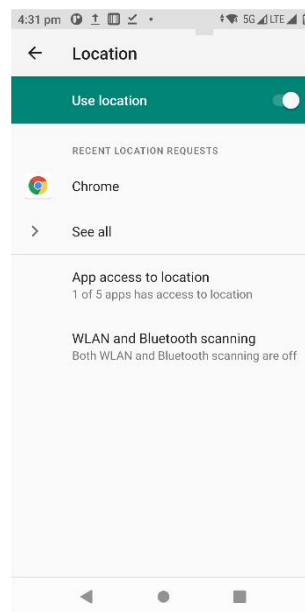



Fig. 7-27 Permission for location information

## 7.11 Security

Find this icon: 

->Settings

->Security

You can set the display lock, fingerprint, device management application, password for installing application of unknown source, SIM card lock, encryption and credentials, fixed applications, etc.

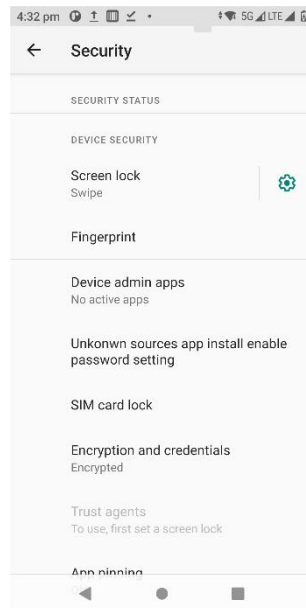



Fig. 7-28 Security

### 7.12 Account

Find this icon: 

- >Settings
- >Account

The account and synchronize information can be created (you can synchronize contact information, calendar, etc., to the cloud of other products after setting an account and server side).

### 7.13 Language and input method

Find this icon: 

- >Settings
- >System
- >Language and input method

With the language selection, text input and automatic error correction options, you can select your favorite keyboard and input method, and set text-to-voice output and pointer speed. If other input methods are installed, they will be displayed on this interface.

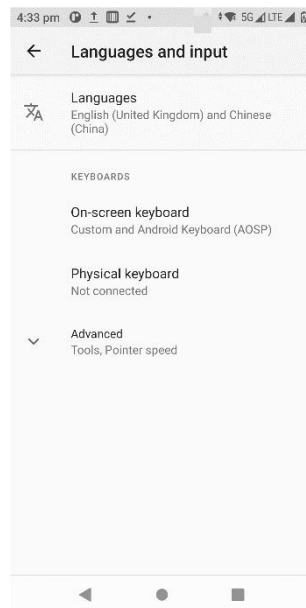



Fig. 7-29 Language and input method

#### 7.14 Backup and reset

Find this icon: 

- >Settings
- >System
- >Advanced
- >Backup and reset

The data can be backed up or restored; the factory settings can be restored.

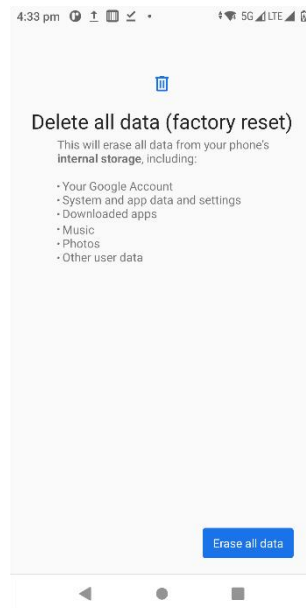



Fig. 7-30 Restore factory settings

### 7.15 Date and time

Find this icon: 

->Settings

->System

->Date and time

The time or time zone can be set automatically as provided on the network or manually set; the time zone, and time and date display format can be selected.

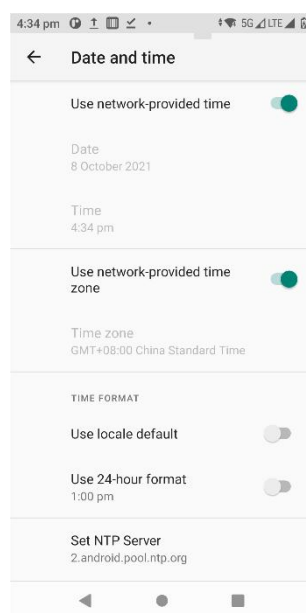

Fig. 7-31 Date and time

### 7.16 Barrier-free function

Find this icon: 

->Settings

->Barrier-free function

Here you can set gestures for zoom-in and high-contrast text, hang up the call by pressing the Power key, set mono audio, color inversion, color calibration and touch and hold delay.

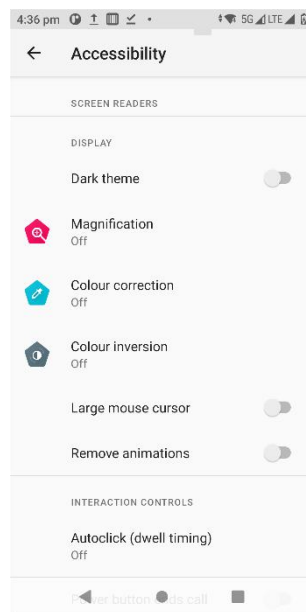



Fig. 7-32 Barrier-free function

### 7.17 Developer options

Find this icon: 

->Settings

->Developer options

Settings-->About phone-->Version; click the version multiple times to open the developer options, and then you can get some other information on the device, which is common to Android.



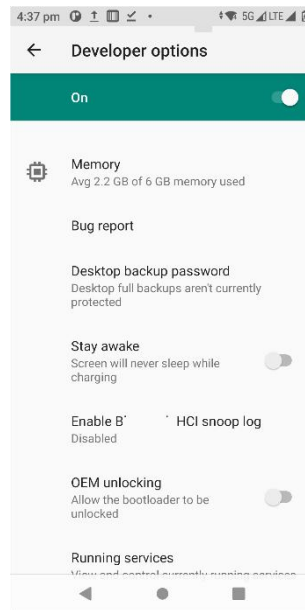



Fig. 7-33 Developer options

## 7.18 About the phone

Find this icon: 

->Settings

->About the phone

Details of the device:

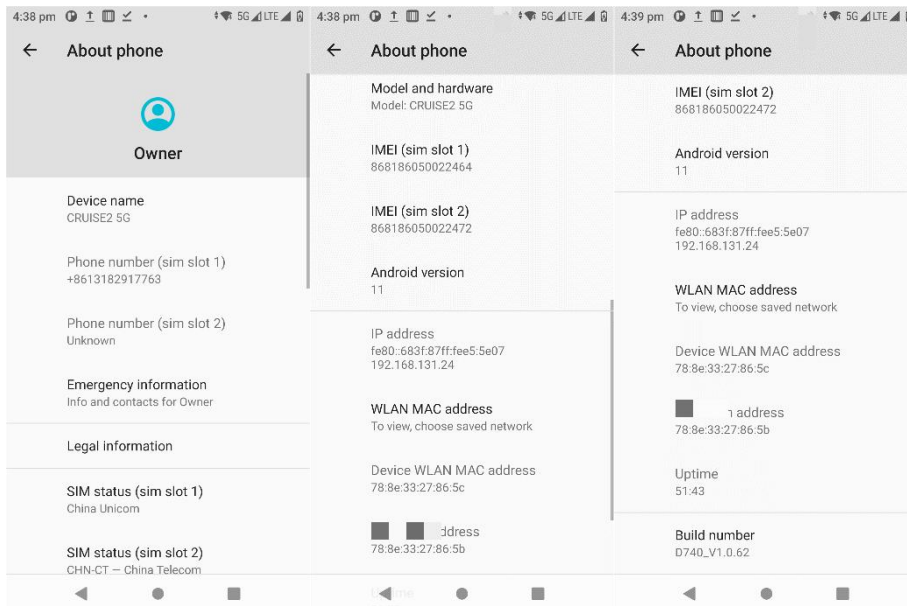

Fig. 7-34 About the phone

1. In the SIM status information, you can view the current network, signal intensity, IMEI number, etc. as shown in Fig. 7-39;

2. Model: The model of the device is displayed;
3. Function number: The function number of the device is displayed;
4. Android version: Version of Android system ;
5. Baseband version: Version of the module;
6. Touch display firmware version: version of the touch display;
7. Serial number: The S/N of the device is displayed;
8. Core version: Core information of the device;
9. Version: Software version of the device.

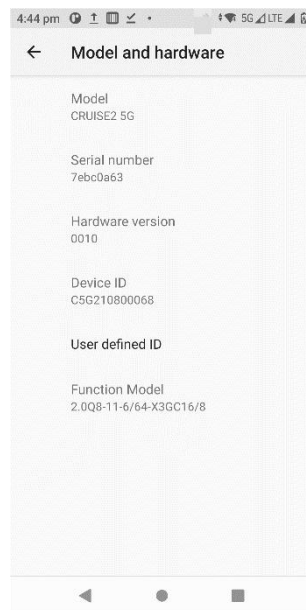



Fig. 7-35 Model & hardware

## Chapter VIII Introduction of typical applications

### 8.1 Scanning tool

1. Find this icon ; open and enter this interface and press the Scan key to start scanning properly.

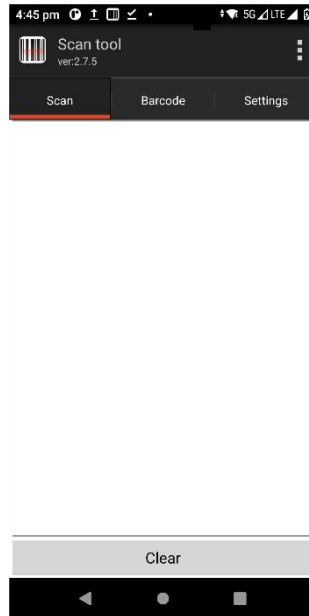

Fig. 8-1 Main interface of the scanning tool

2. Select the [Barcode settings] option to display the barcode type setting interface and set the barcode type as required;

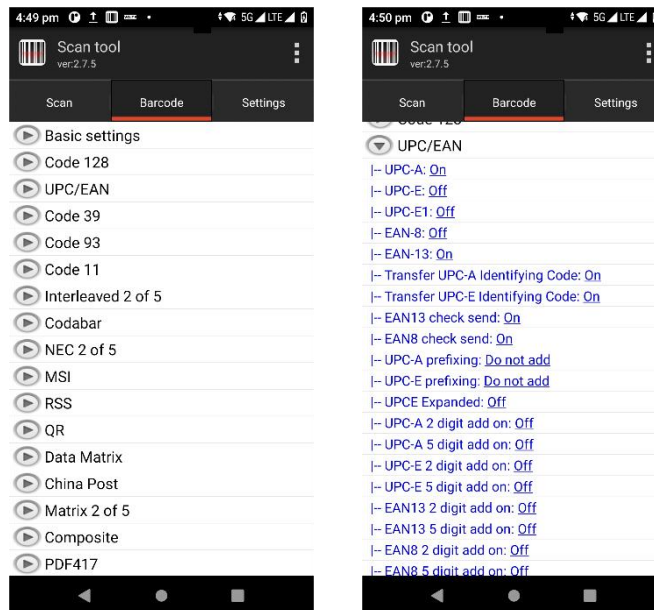

Fig. 8-2 Barcode setting

3. Open the [Basic settings]; you can set the scanning backlight intensity, continuous light mode, exposure and timeout time, etc.:

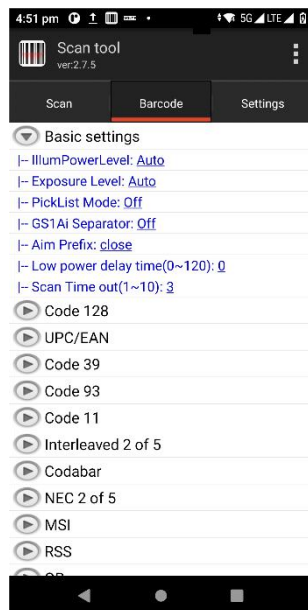

Fig. 8-3 Basic settings

4. Open the [Application settings] option; you can set the basic scanning switch as shown in Fig. 8-4:

- (1) Scanning voice: When it is enabled, there will be a voice prompt when scanning;
- (2) Vibration: When it is enabled, the scanning will be performed with vibration prompt;
- (3) Barcode addition: When it is enabled, the barcodes can be continuously output;
- (4) Automatic clearing: The previous barcode will be automatically cleared after the barcode is scanned;
- (5) Auto-run after power-on: When it is enabled, the scanning program will run automatically when the device is turned on;
- (6) Display barcode type: When it is enabled, the barcode type will be displayed when scanning the barcode;
- (7) Stop scanning upon release: When it is enabled, the scanning light will be off when the scanning key is released, and when the scanning key is pressed, the scanning light will be on continuously in the [scanning duration] and then go off;
- (8) Scan in cycle: When it is enabled, the scan will be automatically and continuously performed;
- (9) Interval time: The interval time can be set by the user, which is the time from the completion of scanning the barcode to the scanning of the next barcode;
- (10) Restoring default barcode setting: You can restore the default settings of the barcode as

shown in Fig. 8-5;

(11) Barcode suffix: You can add the barcode output suffix (numbers, letters, special characters, etc.);

(12) Barcode prefix: You can add barcode output prefix (numbers, letters, special characters, etc.);

(13) End character: You can select the end character of the barcode output, including Enter, Tab, Space, None;

(14) Barcode sending method: You can select the method to send barcodes in the form of focus entry, broadcast, simulated keyboard or clipboard (with simulated keyboard, an input method with hard keyboard needs to be selected) as shown in Fig. 8-6;

(15) Developer options: Enter the password 888888, and you can modify the developer options (not recommended) as shown in Fig. 8-7.

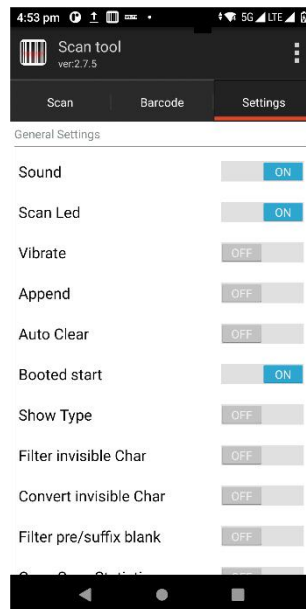

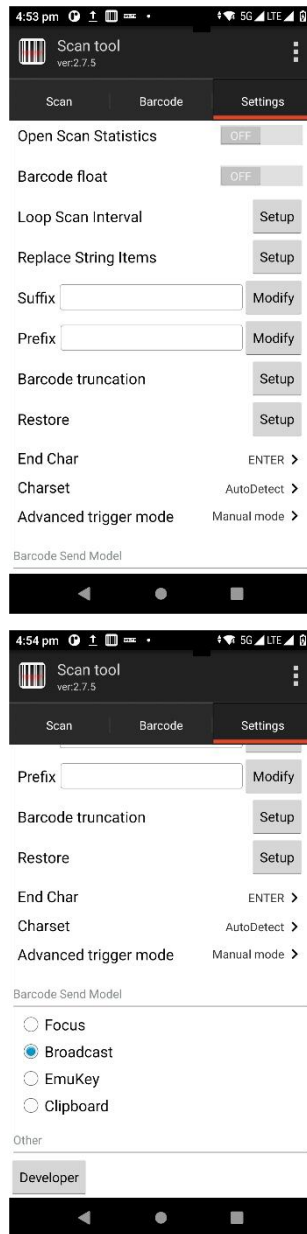

Fig. 8-4 Application settings

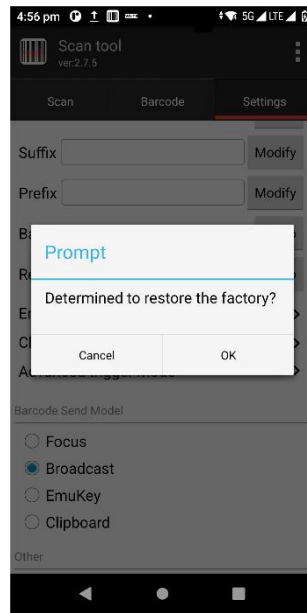

Fig. 8-5 Restoring default barcode settings

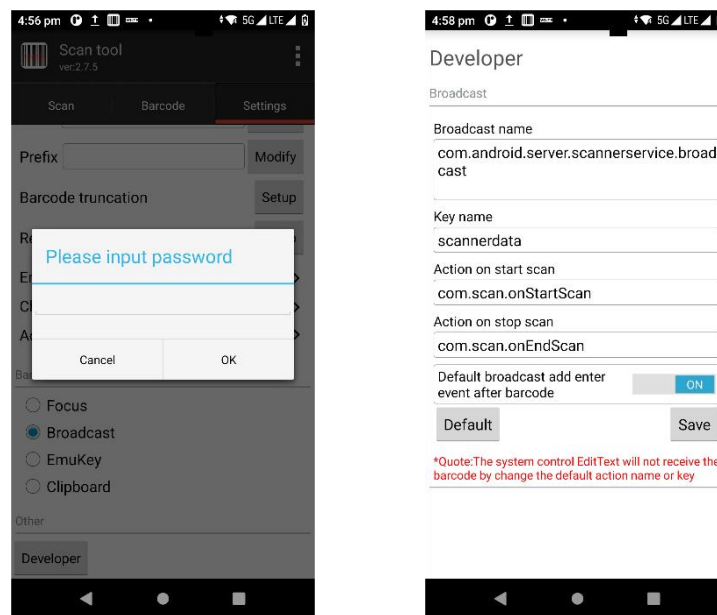

Fig. 8-6 Developer options

### 5. Hide or exit program

(1) Select the [Hide] option, and the program will run in the background; you can scan by pressing the scanned document in any editing interface;

(2) Select the [Exit] option, and the program will be exited and closed.

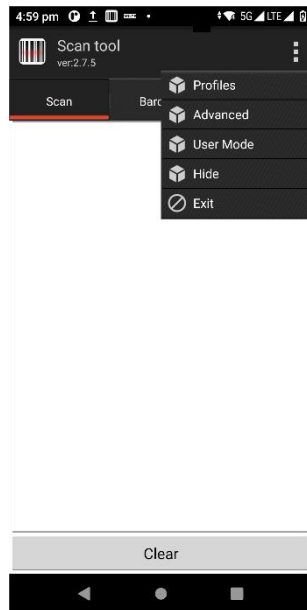

Fig. 8-7 Hide and exit

## 8.2 System upgrade

This application is to facilitate customers to realize remote upgrades.



1. Find this icon **Updater** and enter [System Upgrade] as shown in the figure below:

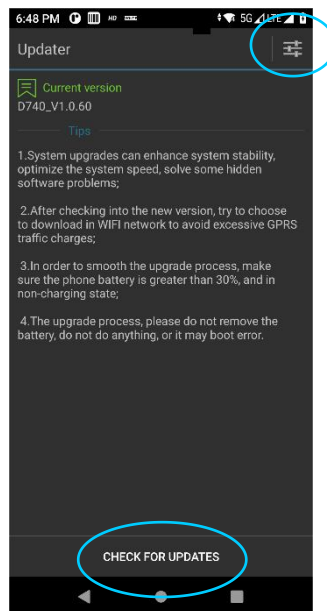

Fig. 8-8 System upgrade

2. When the network is connected properly, click the Check for update key. If there is no update, it will prompt that the current version is the latest version; if there is an update, it will prompt that a new version is found. Click to enter the download interface as shown in the figure.



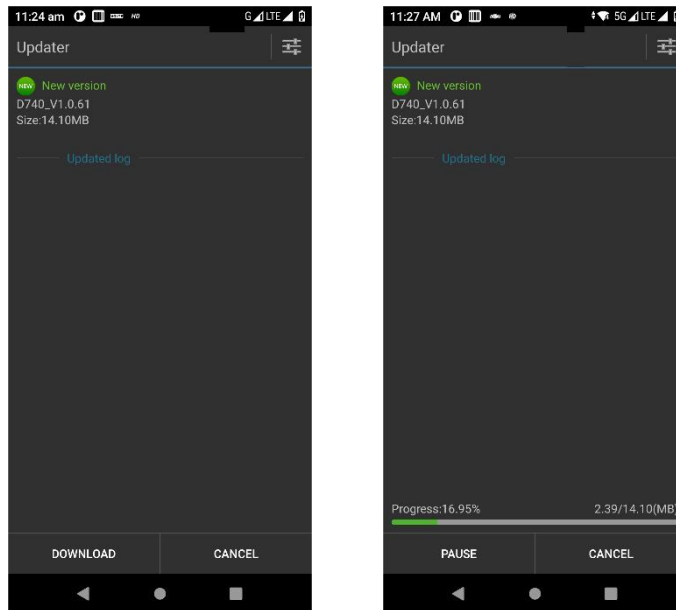

Fig. 8-9 Checking and downloading for update

3. Click the Download key; after the download is successfully completed, click the Update now key, and the device will be automatically restarted in upgrade state as shown in the figure:

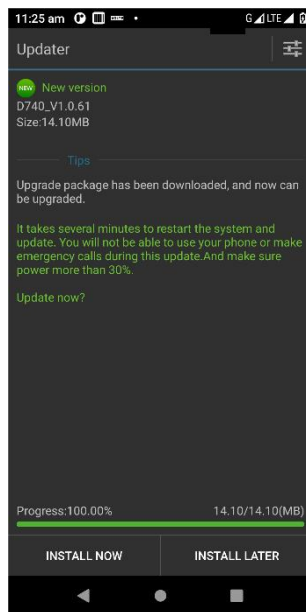

Fig. 8-10 Update now

When the power is less than 30%, the following prompt will appear and the upgrade cannot be performed.

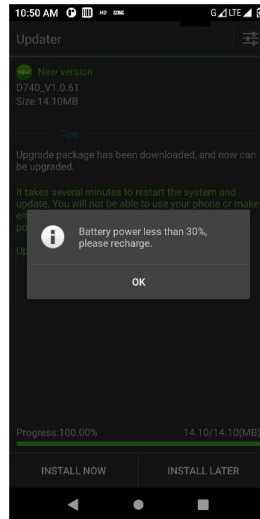

Fig. 8-11 Low battery power

4. The system upgrade can be set as shown in the figure:

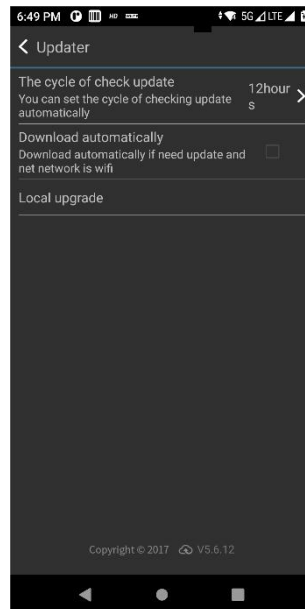

Fig. 8-12 System upgrade

### Description of system upgrade

To upgrade the firmware and system of the terminal with unauthorized third-party software may pose security risks such as the inoperability of the terminal, disclosure of your personal information. It is recommended that you use online upgrade or download the software from the official website that is compatible with the terminal to upgrade. After the terminal is upgraded, all your personal information may be deleted. Please back up your personal information before upgrading.

### 8.3 Mobile Butler

To set permissions required for the customers for hand-held Android terminals, the users are not allowed to use non-designated applications.

1. Find this icon  , Settings—Apps and Notifications—Default apps. Tap the homepage app to enter the settings homepage; select homepage apps->select Mobile Butler, and press the home key to exit and go to the Mobile Butler launcher interface



Fig. 8-13 Default launcher

2. The administrator can set and change the passwords

(1) In the Mobile Butler interface, press the three (Menu) keys in the lower right corner to add desktop options.



Fig. 8-14 Interface without password

As shown in the figure above, the administrator password has not been set, and it needs to be set first. Click the [OK] key to redirect the password modification interface as shown in the figure below:

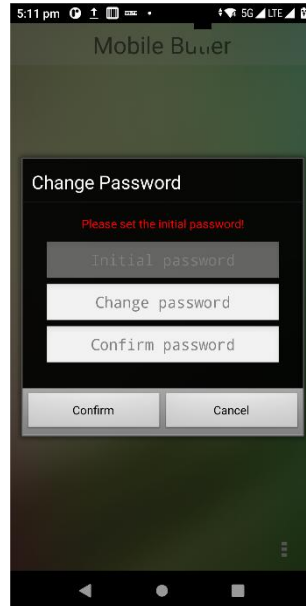

Fig. 8-15 Initial password setting

Set the initial password of the administrator as required, such as 123456; click the OK key, and the password is set successfully. Note: It cannot be left blank and the contents of the updated password field and the confirm password field must be consistent.

(2) Press the three (Menu) keys in the lower right corner again as shown in the figure below:

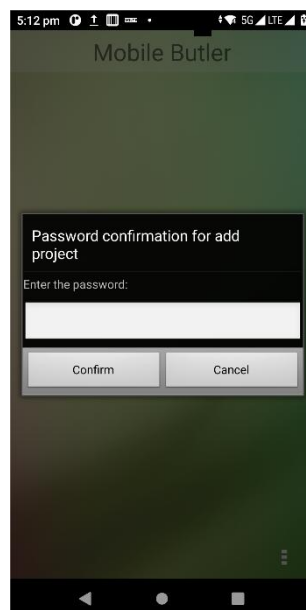

Fig. 8-16 Password input interface

Enter the corresponding administrator password (123456). You can pass the authentication and the interface as shown in the figure below will be displayed:

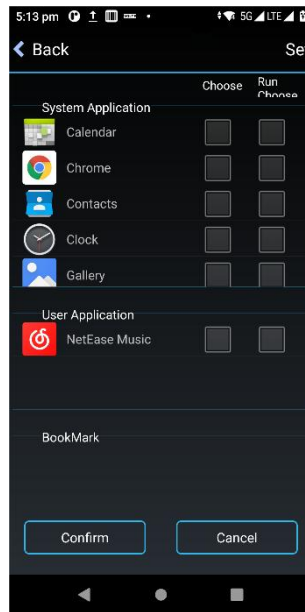

Fig. 8-17 Adding application interface

Select the application to be added to the [Desktop] and click the [OK] key to complete the addition; select an application [Autorun], and the application will be automatically launched when the device is restarted (Note: The only one auto-run application upon power on is currently available) as shown in the figure below:



Fig. 8-18 Main interface

(3) Modification of administrator password

To add an application interface, click [Settings] in the upper right corner to enter the setting interface and click [Modify password] to display the password modification interface:

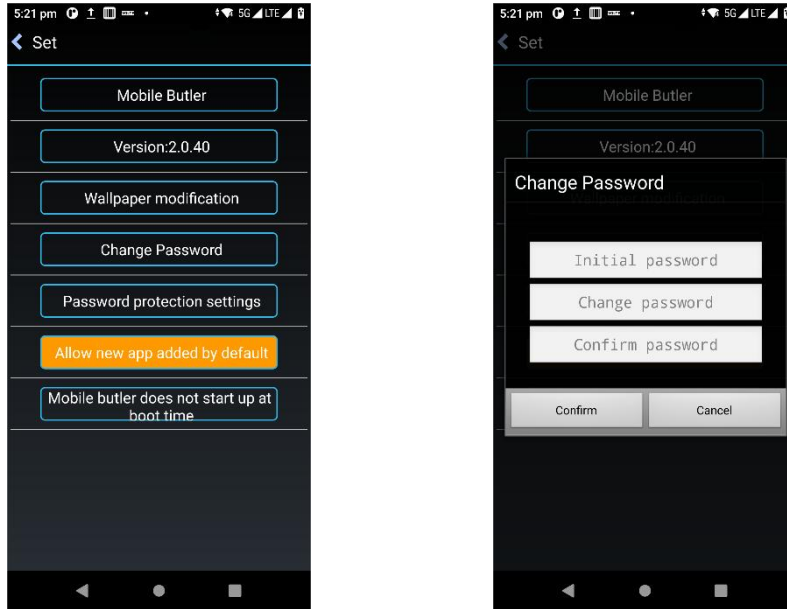

Fig. 8-19 Modifying password

(4) Modification of administrator name

Enter the [Settings] interface and click [Mobile Butler] to modify the name of "Mobile Butler".

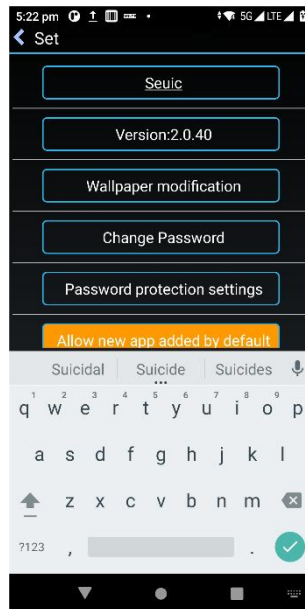

Fig. 8-20 Modification of name

(5) Replacement of wallpaper

Enter the [Settings] interface, and click [Modify wallpaper]; the interface will be displayed as shown in the figure below:

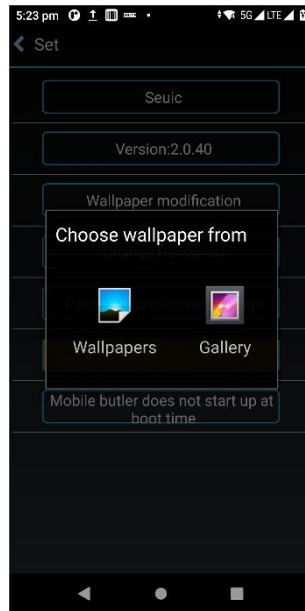

Fig. 8-21 Modification of wallpaper

(6) Clearing default launcher settings

Option 1: Enter [Settings] ----> [Applications] ----> Select [Reset application preferences], and click [Reset Application] to clear the settings.

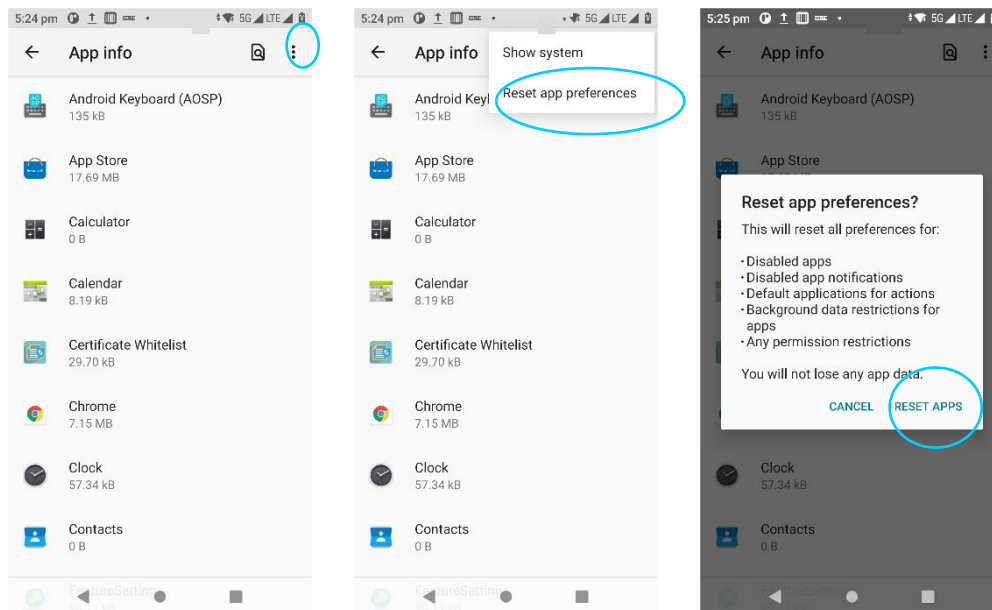

Fig. 8-22 Clearing the default launcher settings 1

Option 2: In the Mobile Butler setting interface, modify the [Autorun Mobile Butler upon power on] to [Mobile Butler not run automatically] as shown in the figure below:

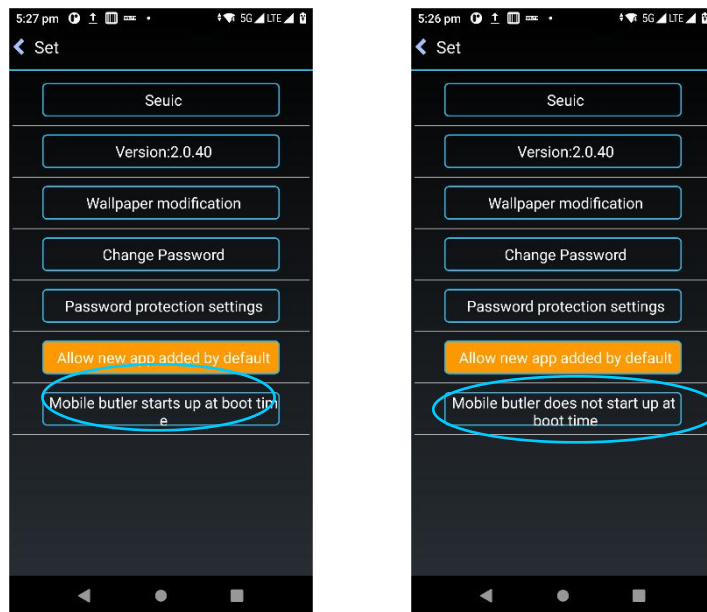

Fig. 8-23 Clearing the default launcher settings 2

Note: The option 2 is recommended. Other application settings will be reset in option 1.



## 8.4 Quick configuration

This application is provided to quickly copy the configuration information of one device to another device of the same type, so that the related configurations of both devices are identical.

The configuration import cannot be implemented between devices of different types.



Find this icon

and enter the quick configuration interface;

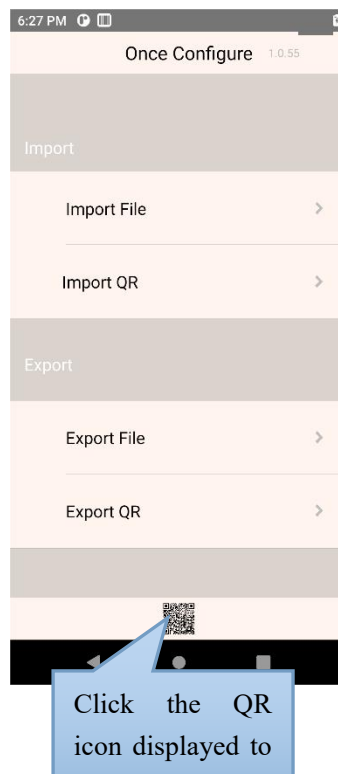

Fig. 8-24 Main interface of quick configuration

### 8.4.1 Import

#### 1. File import

Put the eligible zipped configuration packages in the specified directory of the external SD card, and the path of the external SD card is external SD card/SysSetting/Setinfo.tar.gz.

(1) Manual import:

1) Put the zipped configuration package (with file name of Setinfo.tar.gz) in the external SD card/SysSetting directory as shown in the figure:

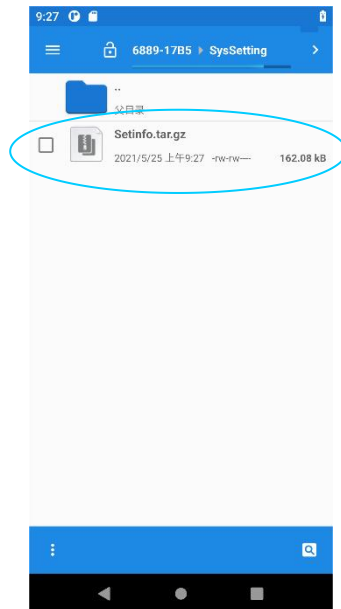

Fig. 8-25 Directory of zipped configuration package

2) Enter the quick configuration interface, and click [File import]; the prompt below will pop up, and click the [OK] key;

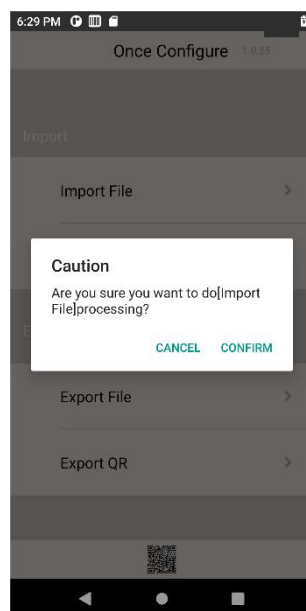

Fig. 8-26 File import

3) After the file is successfully imported, the item and status of the file imported will pop up. After clicking the OK key, a restart prompt will pop up. Click the [Restart now] key to complete import (Some configurations will not take effect immediately if you do not restart the device).

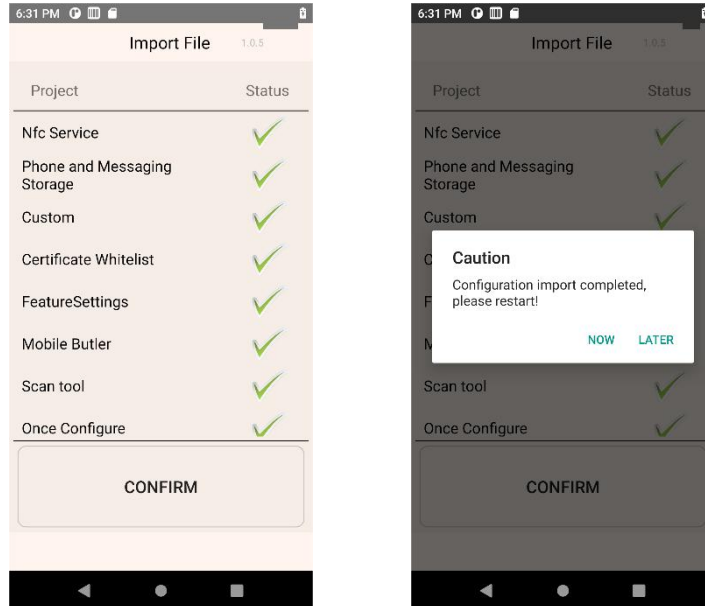

Fig. 8-27 Successfully imported file configuration

## 2. QR code import

This function can be used to import external configuration files by scanning the QR code, and you can call the camera to scan other external QR codes to import the configuration file.

(1) Enter the quick configuration interface, and click the [Import via QR code]; put the QR code to be imported into the scanning box as shown in the figure below:



Fig. 8-28 Import via QR code

(2) After the code is scanned and the file is imported successfully, the item and status imported via QR code will pop up. After clicking the OK key, a restart prompt will pop up. Click the [Restart now] key to complete import (Some configurations will not take effect immediately if you do not restart the device).

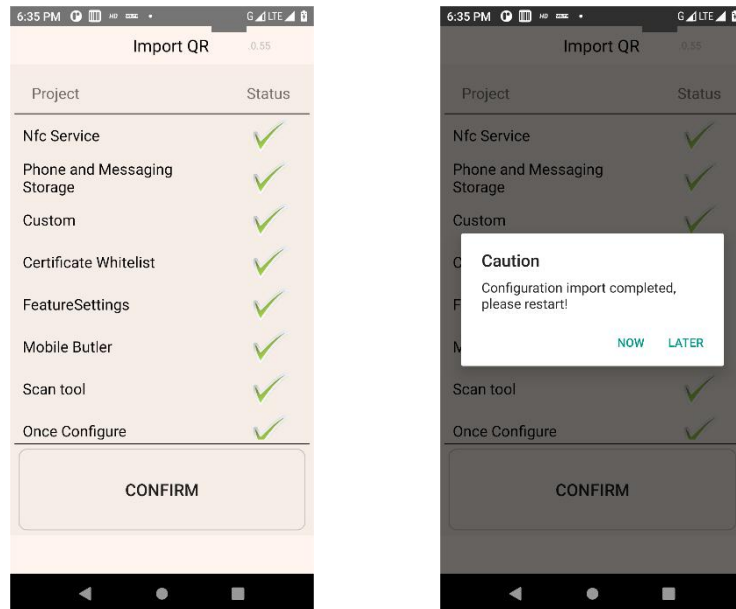

Fig. 8-29 Successfully imported via QR code

### 8.4.2 Export

#### 1. File export

This function is provided to export all the configurations of the device in the configuration import and export tool to the specified directory of the device's built-in SD card or external SD card. The name of the exported file is Setinfo.tar.gz.

The path of the export file is: a) External SD card/SysSetting/

b) Built-in SD card/SysSetting/

When the device is equipped with an external SD card, the file is exported to the external SD card first.

(1) Enter the quick configuration interface, click the [File export] key; the interface below will pop up to indicate that the file is successfully exported; when there is a configuration file in the external SD card, there will be a prompt that the file exported again will overwrite the original one:

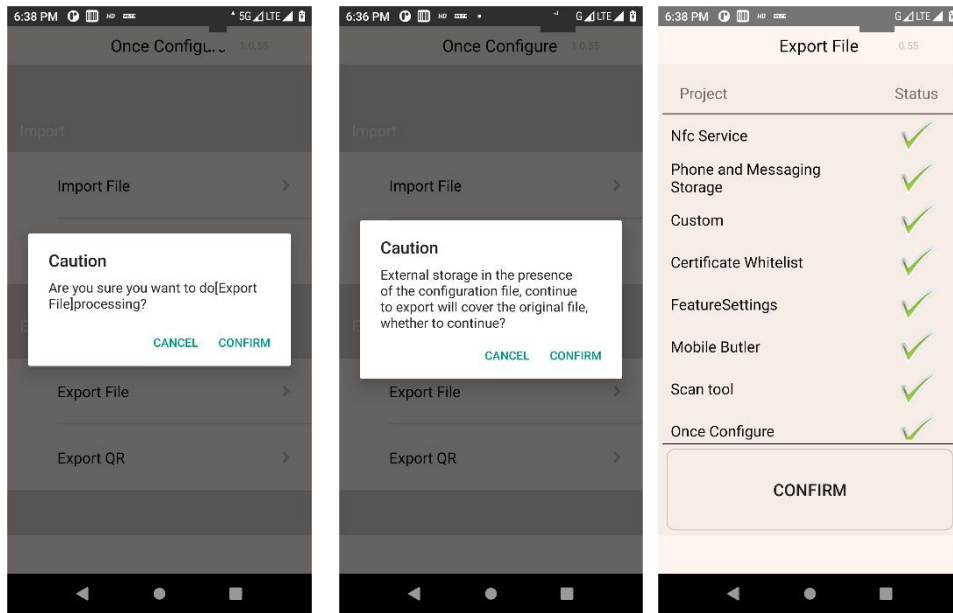

Fig. 8-30 File export

(2) The exported file name is Setinfo.tar.gz; you can view it in [File Management] ----> [Phone Memory] OR [External Memory Card] ----> [SysSetting]:

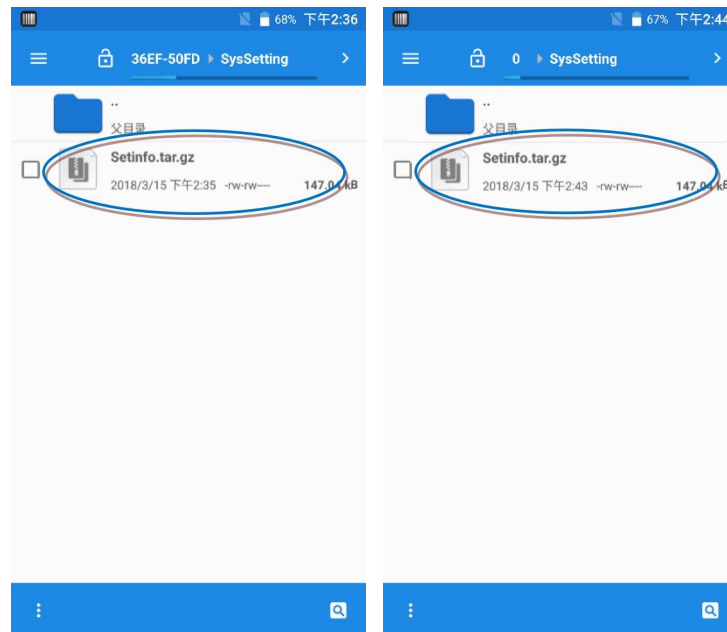

Fig. 8-31 File export path

## 2. Export via QR code

A QR code can be generated for export via QR code; scan the QR code to connect to the channel and transmit configuration files.

(1) Enter the quick configuration interface, and click the [Export via QR code] key; the interface below pops up to indicate that the file is successfully exported; click the OK key:

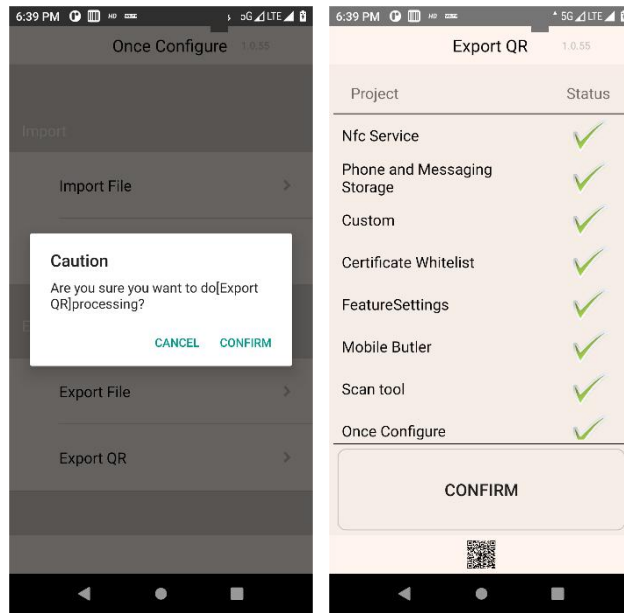

Fig. 8-32 Export via QR code

(2) The generated QR code image is at the bottom of the application; click the small QR code icon to view it.



Fig. 8-33 QR code image

### 8.5 Featured settings

This application is used to quickly realize the special needs of customers, which is convenient for customers to use this device quickly.

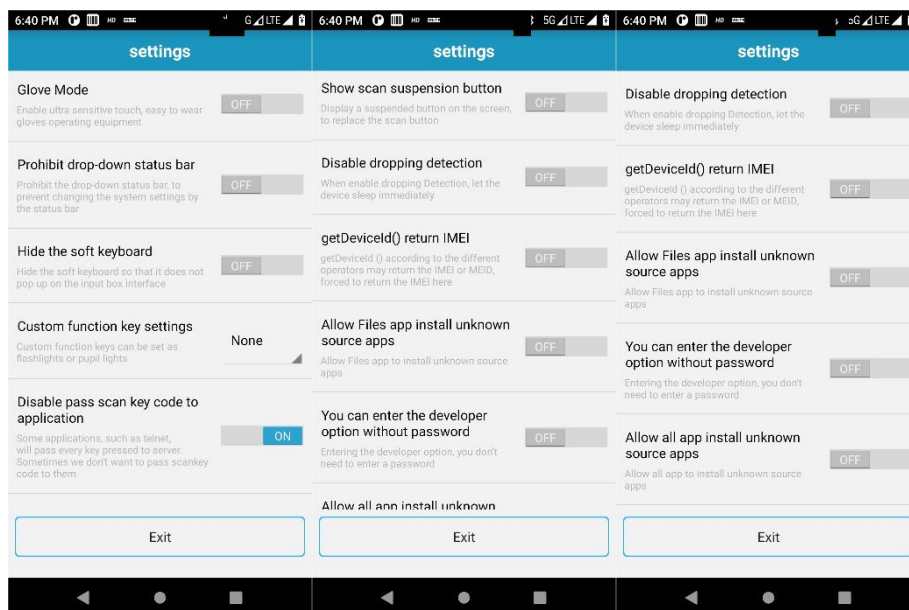

Fig. 8-34 Featured settings

### 8.5.1 Touch display glove mode

Enable this function to support the operation of the touch display with gloves and the sensitivity of the touch display is high at this time;

### 8.5.2 Disabling status pull-down

Enable

This feature takes effect immediately, and the menu cannot be pulled down.

Disable

This function takes effect immediately, and the menu can be pulled down properly

### 8.5.3 Disabling transfer of key value from scan key to applications

Enable

Some applications such as the Telnet program will transmit all the pressed key values the server

Disable

In some cases, the disabled applications such as Telnet programs will transmit all the pressed key values to the server

### 8.5.4 Displaying scan Floating Action Key(FAB)

Disable

The scan FAB is not displayed at the bottom of the interface

Enable

The scan FAB is displayed at the bottom of any interface of the device; click it once, and the scanning head emits light to scan the barcode properly

### 8.5.5 Disabling drop detection

Disable

If the device accidentally falls, the system will automatically detect and enter the display sleep mode

Enable

If the device accidentally falls, the system will not shut down and sleep

### 8.6 Whitelist of digital certificates

This software is used to add the specified digital certificates to the whitelist. Applications signed with the digital certificate in the whitelist are allowed to be installed directly without opening the option "Unknown Source". The default password for the application is 4007770876.

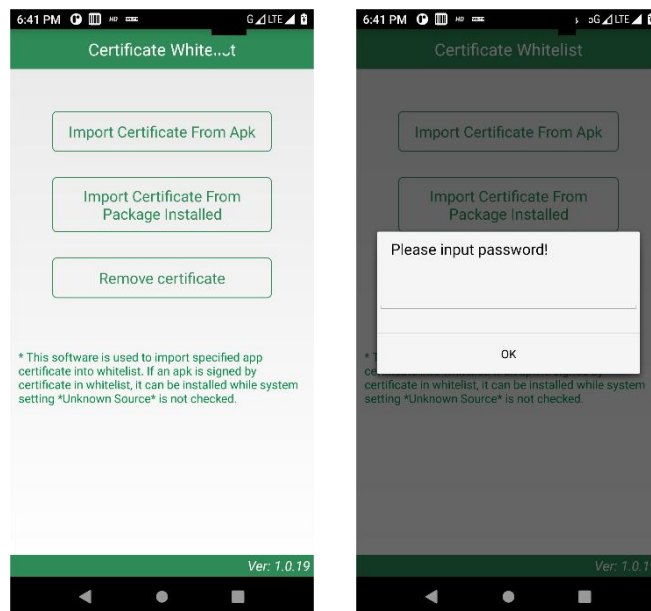

Fig. 8-35 Whitelist of digital certificates



1. Import the certificate in the APK file

The application will search for all APK files in the internal storage device directory, and display their file name and directory. The user can import the certificate in the selected APK file into the system by clicking the [Import] key after selecting single or multiple items displayed.

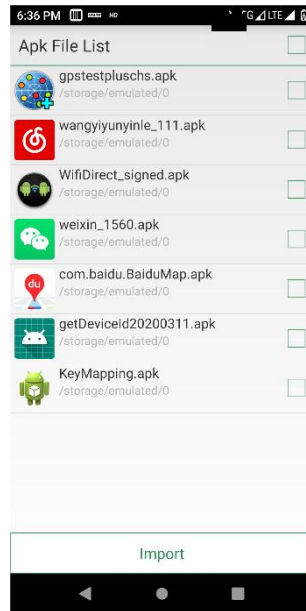

Fig. 8-36 APK file import list

2. Import the certificate in the installed package

The application will display the name of the third-party APP installed in the system and its package name. The user can click the [Import] key after selecting single or multiple items displayed to import the certificate in the selected APK file into the system.

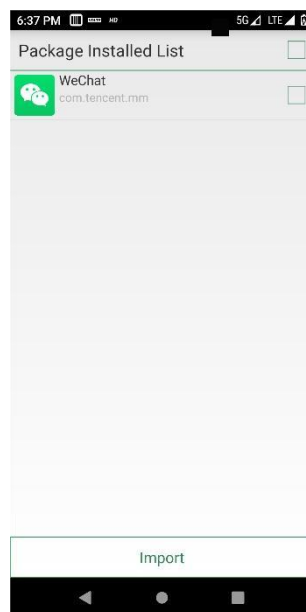

Fig. 8-37 Name list of installed packages

### 3. Deleting the certificate from the whitelist

The application will display the name of the certificate that has been added. Check single or multiple items displayed and click the [Delete] key to delete the corresponding certificate from the whitelist. The items displayed that are grayed out without a check box are the default certificates and cannot be deleted.

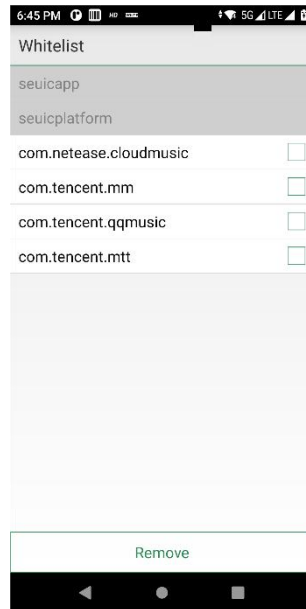

Fig. 8-38 Types of signature whitelist

#### Precautions:

The added certificate will be named after the package name of the APP.

For certificates with the same content but different package names, only one record entry is saved, and it is named after the first record saved.

## Chapter IX Troubleshooting

Fault	Cause	Solution
After pressing the Power key, the CRUISE2 is not turned on	The battery power is too low or it is not charged	Charge the battery or replace the battery
	It is pressed in a short time	Press and hold it for 3 seconds
	The battery is not loaded correctly	Load the battery correctly
	System is crashed	Perform soft reset
The rechargeable battery can no longer be charged	The battery is faulty	Replace the battery
	The battery temperature is too high/low	Keep the battery in the permitted temperature range
No voice heard	The volume set is too low or muted	Adjust the volume
CRUISE2 is powered off automatically	The CRUISE2 is in inactive mode	After a period of inactivity, the mobile data terminal will be shut down; You can set this time period from 15S to 30Min, or never sleep.
	The battery is out of power	Charge the battery or replace the battery
CRUISE2 fails to decoded when reading the barcode	The scanning tool program is not started	Upload the scanning application to CRUISE2.
	It is in the barcode setting or application setting interface	Set the scanning program to the scanning interface, or hide the scanning program
	The barcode is not readable	Ensure that the barcode is free of defects
	The barcode decoding function is not enabled	Enter the barcode setting and enable the corresponding decoding function
	CRUISE2 is not compatible with this barcode type	
	The distance between the CRUISE2 and the barcode is not suitable	Put the CRUISE2 in the correct scanning range
Unable to connect to the AP	"Authentication error" is displayed	The WLAN password is incorrect

Unable to take photos	"No storage device" is prompted	Exit the USB storage mode
	"Camera failure" is prompted	Turn off the 2D; the camera cannot be turned on when the 2D light is emitted
	"Insufficient SD card space" is prompted	Clear the memory or change the storage location
Unable to access mobile network	Mobile data is not enabled	Enter settings to enable mobile network
	The network mode is incorrectly selected, and the SIM card is not registered	Enter the settings and select the correct network mode
	SIM card out of service due to arrears	Top up the SIM card in time

## **Optional accessories**

Please keep the original box and packaging materials for future repair or storage of the device. The accessories listed below can improve your work efficiency, which can be bought as appropriate.

- ◆ 1 set of CRUISE2 5G series product
- ◆ 1 piece of USB cable
- ◆ 1 piece of adapter